

Prevailing Torque Type Hexagon Nuts (with non-metallic insert)

DIN 982 High Type

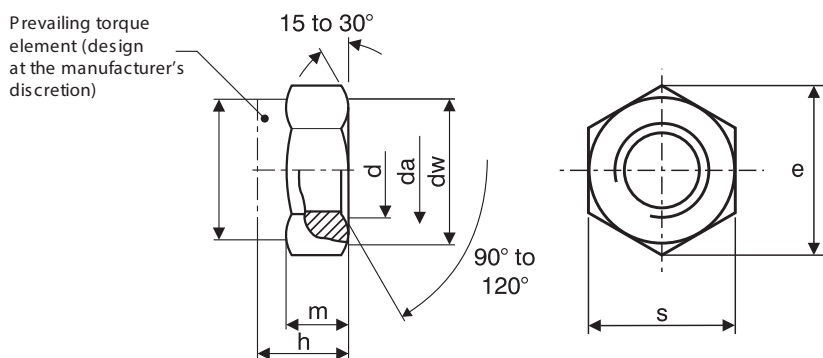

DIN 982 Dimensions of nuts

Nominal size and thread diameter d	p ¹	da		dw	e		h		m ²	m	s	
	(coarse pitch series)	min.	max.	min.	min.	nom.	min.	nom.	min.	min.	min.	nom.
M5	0.80	5.00	5.75	6.9	8.79	6.00	6.30	4.40	3.52	7.78	8.00	
M6	1.00	6.00	6.75	8.9	11.05	7.70	8.00	4.90	3.92	9.78	10.00	
M7	1.00	7.00	7.75	9.6	12.12	8.20	8.50	6.14	4.91	10.73	11.00	
M8	1.25	8.00	8.75	11.6	14.38	9.14	9.50	6.44	5.15	12.73	13.00	
M10	1.50	10.00	10.80	15.6	18.90	11.14	11.50	8.04	6.43	16.73	17.00	
M12	1.75	12.00	13.00	17.4	21.10	13.64	14.00	10.37	8.30	18.67	19.00	
M14	2.00	14.00	15.10	20.5	24.49	15.30	16.00	12.10	9.68	21.67	22.00	
M16	2.00	16.00	17.30	22.5	26.75	17.30	18.00	14.10	11.28	23.67	24.00	
M18	2.50	18.00	19.50	24.9	29.56	19.16	20.00	15.10	12.08	26.18	27.00	
M20	2.50	20.00	21.60	27.7	32.95	20.70	22.00	16.90	13.52	29.16	30.00	
M22	2.50	22.00	23.70	29.5	35.03	23.70	25.00	18.10	14.48	31.00	32.00	
M24	3.00	24.00	25.90	33.2	39.55	26.70	28.00	20.20	16.16	35.00	36.00	

Prevailing Torque Type Hexagon Nuts (with non-metallic insert)

DIN 982 High Type

Specification for nuts and reference standards

Characteristic		Standard
Material		Steel
General Requirements		As specified in DIN 267 Parts 1 and 15.
Thread	Tolerance	6H ^a
	As specified in	DIN 13 Part 12 and 15.
Mechanical Properties (nut body)	Property Class (material)	d ≤ M39: 5, 6 ^b , 8, or 10. d > M39: by agreement.
	As specified in	DIN 267 Part 4.
Material (insert)		Non-metallic, e.g. polyamide.
Performance (prevailing torques)		As specified in DIN 267 Part 15.
Limit deviations and geometrical tolerances	Property Grade	For sizes up to M16: A (previously, design m). For sizes over M16: B (previously, design mg).
	As specified in	ISO 4759 Part 1
Surface finish	As processed.	
	DIN 267 Part 2 shall apply with regard to surface roughness.	
	DIN 267 Part 20 shall apply with regard to permissible surface discontinuities.	
	DIN 267 Part 9 shall apply with regard to electroplating.	
Acceptable inspection		DIN 267 Part 5 shall apply with regard to acceptance inspection.
a See DIN 267 Part 15 in this respect.		
b Only for fine thread nuts.		